

MOBILE CONDIMENT CART

PERFECTION



MODEL# UC4P4HP-CT

Perfection Equipment, Inc.
Perfecta Stainless Division



FEATURES

- (4) DROP IN HAND PUMP DISPENSERS WITH PRODUCT LABELS.
- 2 OR 3 QUART PRODUCT CAPACITY FOR EACH HAND PUMP (REFILLABLE).
- TWO LOCKING CASTERS & TWO FIXED CASTERS
- ALL STAINLESS STEEL CONSTRUCTION

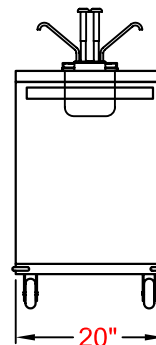
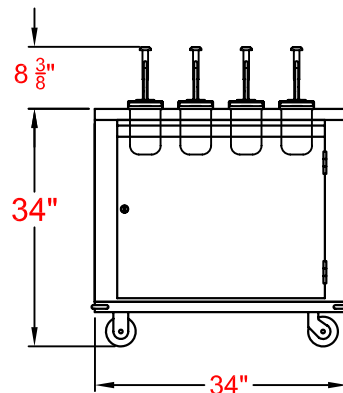
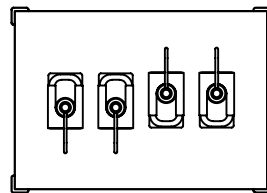

SERVICE AVAILABLE FROM OUR NATIONAL NETWORK



PERFECTION Equipment, Inc.

4259 Lee Avenue, Gurnee, Illinois 60031 Phone: 847-244-7200 Fax: 847-244-7205 Toll Free: 800-356-6301
Website: www.perfectequip.com Email: sales@perfectequip.com

Rev. 09/06/2019