

MOBILE CONDIMENT CART

PERFECTION



Perfection Equipment, Inc.
Perfecta Stainless Division

MODEL# UC2P4QS-CT CUSTOM



FEATURES

- ALL STAINLESS STEEL CONSTRUCTION
- 6 GALLON CONDIMENT CAPACITY FROM (4) 1.5-GALLON BAGS
- (4) 1-PRODUCT PERFECTA QUICK SERVE UNIT WITH MANUAL HAND PUMP
- PRODUCT LABELS (2) KETCHUP (2) MUSTARD
- (4) IN-COUNTER NAPKIN DISPENSERS
- (2) 12 x 20 x 6-1/2" INSULATED FOOD WELLS WITH PANS AND HINGED LIDS
- DUAL-SIDED FOOD GUARD WITH STAINLESS STEEL FRAME AND TEMPERED GLASS PANELS, AFFIXED TO CART
- FULL PERIMETER BUMPER
- LOCKING ACCESS DOORS
- (2) FIXED AND (2) SWIVEL, LOCKING HEAVY DUTY WHEELS
- FULL PERIMETER STAINLESS STEEL SKIRT CONCEALS WHEELS

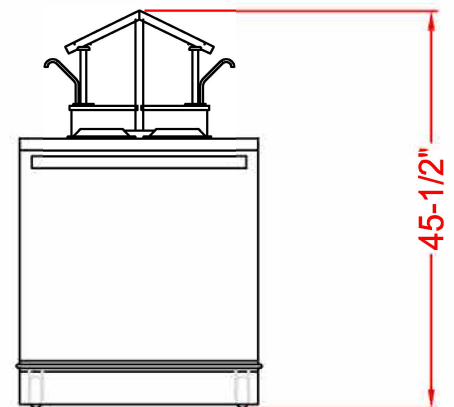
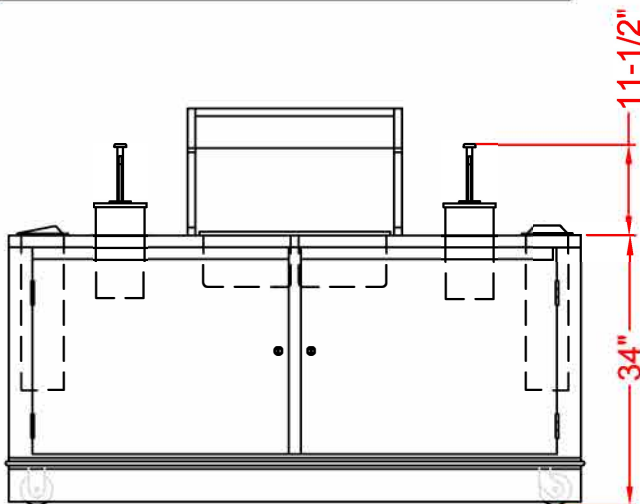
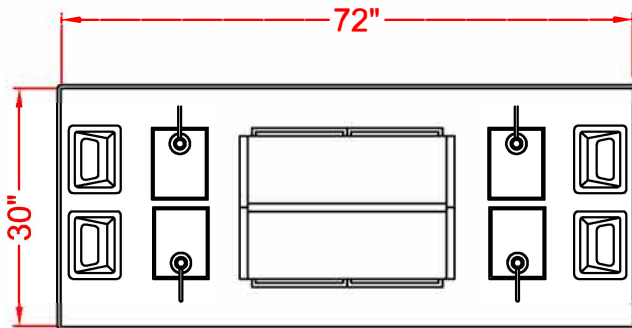

PERFECTION Equipment, Inc.

4259 Lee Avenue, Gurnee, Illinois 60031 Phone: 847-244-7200 Fax: 847-244-7205

Toll Free: 800-356-6301 Website: www.perfectequip.com Email: sales@perfectequip.com



Rev. 09/06/2019