

MOBILE CONDIMENT CART

PERFECTION



Perfection Equipment, Inc.
Perfecta Stainless Division

MODEL# UC2P4QS-CT CUSTOM



FEATURES

- ALL STAINLESS STEEL CONSTRUCTION
- 6 GALLON CONDIMENT CAPACITY FROM (4) 1.5-GALLON CRYOVAC BAGS
- (4) RECESSED PERFECTA QUICK SERVE UNITS WITH CRYOVAC FITTING AND HINGED STAINLESS STEEL MOUNTING BOX
- PRODUCT LABELS (to be determined)
- (4) IN-COUNTER NAPKIN DISPENSERS
- (2) 2-COMPARTMENT KONDI-KEEPERS
- FULL CORNER BUMPERS
- LOCKING ACCESS DOORS
- (4) CASTERS (2-SWIVEL/2-FIXED).
- ADA COMPLIANT

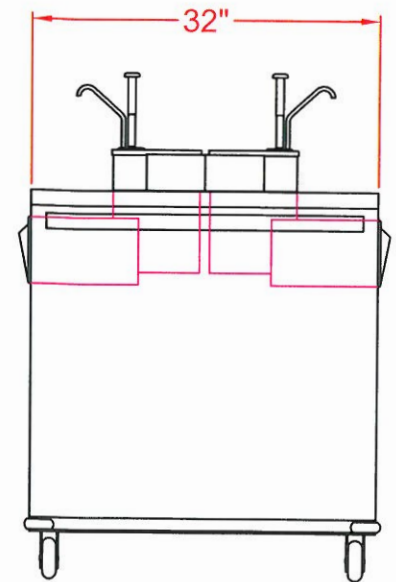
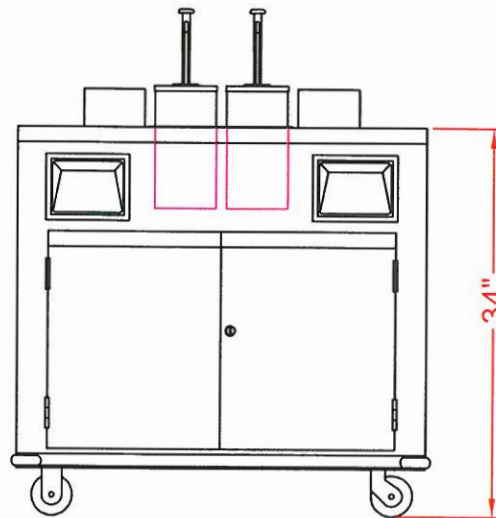
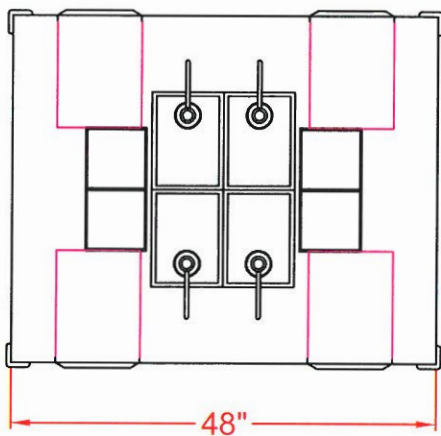

SERVICE AVAILABLE FROM NATIONAL NETWORK

- Service Agencies Established and Trained
- Service Agencies Available where You need them and when You want them

Rev. 09/06/2019



PERFECTION Equipment, Inc.

4259 Lee Avenue, Gurnee, Illinois 60031 Phone: 847-244-7200 Fax: 847-244-7205 Toll Free: 800-356-6301
Website: www.perfectequip.com Email: sales@perfectequip.com



PERFECTA QUICK-SERVE (MANUAL HAND PUMP)

PERFECTION

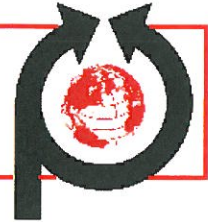

Perfection Equipment, Inc.
Perfecta Stainless Division



PP1000 HAND PUMP SHOWN WITH
1 1/2-GALLON CRYOVAC BAG



SHOWN IN LOADING POSITION

DESCRIPTION

To Be Used With 1 1/2-Gallon Cryovac Product Bag
Perfecta Quick-Serve, Includes – PP1000 Hand Pump, Bag Fitting and Stainless Steel Box
Hinged Top And Front for Easy Loading of Bag

PERFORMANCE

Product: Smooth Sauces, No Particulate
1/2 Ounce Portion Every Pump
No Disassembly Required For Sanitizing (**Clean-in-Place**)
No Drip Spout

INSTALLATION

To Be Mounted on Top of Counter or Recessed Into Counter
6 1/4" Wide x 8 1/4" Deep Cut-Out Required to Recess Into Counter

Approximate Ship Weight: 10 pounds

Key Chemical Tested and NSF Approved for Condiments and Dairy Products



PERFECTION Equipment, Inc.

4259 Lee Avenue, Gurnee, Illinois 60031 Phone: 847-244-7200 Fax: 847-244-7205 Toll Free: 800-356-6301
Website: www.perfectequip.com Email: sales@perfectequip.com

M:\Cut Sheet